



STUART MODELS



Gas Supply & Burners

KEY

- 1) Ceramic Burner (size and shape vary)
- 2) Gas Jet
- 3) Gas Pipe (Lengths vary)
- 4) Disposable Gas Can Regulator
- 5) Refillable Gas Tank and Adaptor (sizes vary)

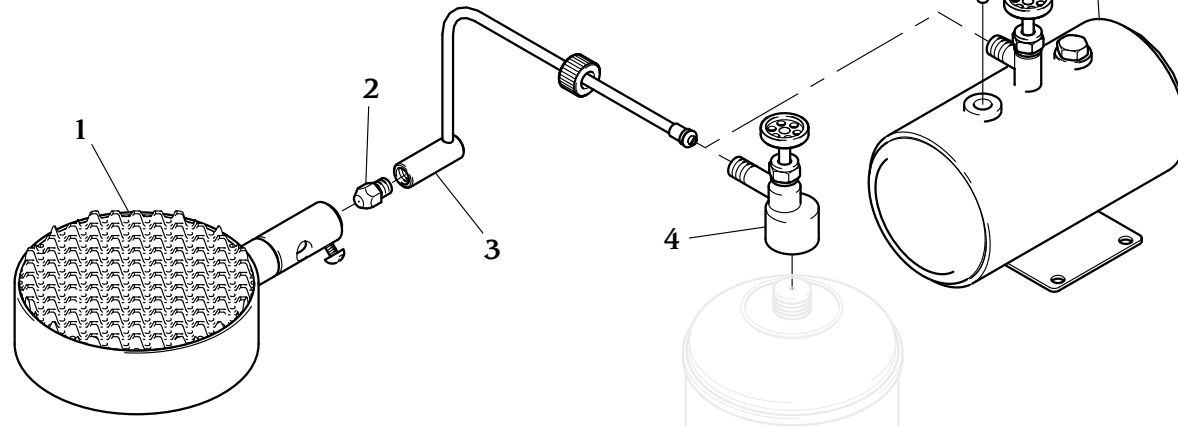

Gas Jets



PART No.	DESCRIPTION
34-50-40206	No.5 gas jet.
34-50-41156	No.6 gas jet.
34-50-40061	No.8 gas jet.
34-50-40118	No.16 gas jet.

Gas Pipes

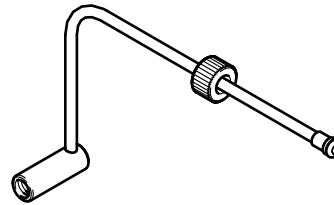

PART No.	DESCRIPTION
34-50-41118	3 1/2 in. gas pipe.
34-50-41044	5 1/4 in. gas pipe.
34-50-40322	8 in. gas pipe.
34-50-40325	18 in. gas pipe.

Gas pipes are supplied in a range of lengths to allow choice when designing the layout of your boiler and gas supply.

Gas Supply Setup

Before using your ceramic burner, please ensure the gas jet is sealed into the jet holder on the gas pipe. We recommend using a medium strength thread locking adhesive with sealing properties (for example Loctite 243 or equivalent).

To light the burner, apply a flame over the ceramic and turn on the gas. When the burner is alight slowly turn up the gas to give full gas flow.

In use, once the burner has warmed up, carefully move the jet holder in or out of the burner tube to obtain maximum output from the burner. Once the correct position has been achieved the jet holder can be locked into position using the screw on the burner tube. Care should be taken over the positioning as it can greatly effect the output of the burner.

Gas Can Regulator



PART No.	DESCRIPTION
34-50-10163	Gas can regulator.

The regulator is to connect the readily available disposable gas cans directly to your gas set up. It also allows you to control the flow of gas to your burner.

3/4 in. dia. Burner



PART No.	DESCRIPTION
34-50-40177	3/4 in. dia. Ceramic Burner (use No.8 jet).
34-50-40184	Adaptor ring.

Size excluding burner tube is 1 7/32 in. dia x 1 3/4 in. high.

This burner fits a 28 mm od fire tube. The adaptor ring allows it to fit a 35 mm od. x 1.2 mm thick fire tube.

2 in. dia. Burner



PART No.	DESCRIPTION
34-50-40661	2 in. dia. Ceramic Burner (use No.8 jet).

Size excluding burner tube is 2 1/8 in. dia x 1 1/4 in. high.

2 1/2 in. dia. Burner



PART No.	DESCRIPTION
34-50-40200	2 1/2 in. dia. Ceramic Burner (use No.8 jet).

Size excluding burner tube is 2 5/8 in. dia x 1 1/4 in. high.

7/8 in. x 2 1/2 in. Burner



PART No.	DESCRIPTION
34-50-40280	7/8 in. x 2 1/2 in. Ceramic Burner (use No.8 jet).

Size excluding burner tube is 1 in. x 2 5/8 in. x 1 1/4 in. high.

1 7/8 in. x 2 1/2 in. Burner



PART No.	DESCRIPTION
34-50-40275	1 7/8 in. x 2 1/2 in. Ceramic Burner (use No.8 jet).

Size excluding burner tube is 2 in. x 2 5/8 in. x 1 1/4 in. high.

1 7/8 in. x 5 1/8 in. Burner



PART No.	DESCRIPTION
34-50-40293	1 7/8 in. x 5 5/8 in. Ceramic Burner (use No.16 jet).

Size excluding burner tube is 2 in. x 5 1/4 in. x 1 1/4 in. high.

Refillable Gas Tanks



The medium refillable gas tank has a 2 in. dia. x 3 11/16 in. long barrel. The overall height including regulator valve is 3 3/8 in.

Refillable gas tanks were primarily developed for use in model boats where there was insufficient space to fit a disposable gas cylinder. Please note only low pressure butane/propane mix gas (ratio 70/30) should be used.

CONTENTS

Brass gas tank silver soldered and pressure tested at the factory with integral regulator valve and standard gas tank refill adaptor.

PART No.	DESCRIPTION
34-50-32520	Medium refillable gas tank with adaptor.

The large refillable gas tank has a 2 1/2 in. dia. x 4 1/8 in. long barrel. The overall height including regulator valve is 3 13/16 in.

The large gas tank is best used with our range of larger boilers, although can be used with smaller boilers for extended running times. Please note only low pressure butane/propane mix gas (ratio 70/30) should be used.

CONTENTS

Brass gas tank silver soldered and pressure tested at the factory with integral regulator valve and standard gas tank refill adaptor.

PART No.	DESCRIPTION
34-50-32525	Large refillable gas tank with adaptor.

Gas Tank Refill Adaptors



PART No.	DESCRIPTION
34-50-10115	Gas tank refill adaptor (standard).
34-50-10275	Gas tank refill adaptor (long).

The gas tank refill adaptors are used to charge the refillable gas tanks. The standard adaptor is 2 1/4 in. long whilst the long adaptor is 4 1/2 in.

Prices

Part No.	Page	Price £	Part No.	Page	Price £
34-50-40206	1	4.00	34-50-40184	2	4.00
34-50-41156	1	4.00	34-50-40661	2	48.00
34-50-40061	1	4.00	34-50-40200	2	56.00
34-50-40118	1	4.00	34-50-40280	2	42.00
34-50-41118	1	12.00	34-50-40275	2	48.00
34-50-41044	1	12.00	34-50-40293	2	56.00
34-50-40322	1	12.00	34-50-32520	3	93.00
34-50-40325	1	12.00	34-50-32525	3	107.00
34-50-10163	1	19.00	34-50-10115	3	15.50
34-50-40177	2	42.00	34-50-10275	3	15.50

STUART MODELS

Braye Road, Vale, Guernsey, UK, GY3 5XA.

Telephone 01481 242041 Fax 01481 247912

www.stuartmodels.com